

TruSABER

Description

Exposed chrome plated flush valve for 1 1/2" back entry Eastern Squat Toilets.

Flush Cycle

1.6 gpf / 6.0 Lpf Low Consumption

Specification

- Diaphragm Operation
- Upper Chamber Regulating Screw for "True-in-the-Field" water conservation.
- Mashaerator self-cleaning bypass diaphragm.
- Scratch Proof Recessed Hex-nut designed cover.
- ADA compliant metal "Rubberflex" oscillating handle.
- Renewable main valve seat.
- 1" vandle proof TruStop ball valve designed angle control stop with TruChek.
- Sweat adapter kit.
- SlipFit adjustable tailpiece.
- 1-1/2" x 36" x 5" vacuum breaker flush connection with elbow for back entry Eastern Squat Toilets.
- All rubber parts molded of chloramine resistant rubber.

Variations

- AM - Antimicrobial Coated Handle
- O - 1-1/4" Flush Connection
- SQT8 - 1-1/2" x 36" x 8" vacuum breaker flush connection with elbow for back entry
- T36 - Solid ring wall support for flush connection

Valve is certified to be in compliance to the applicable sections of ASSE 1037 and ANSI/ASME 112.19.2



Patented TruStop Control Stop

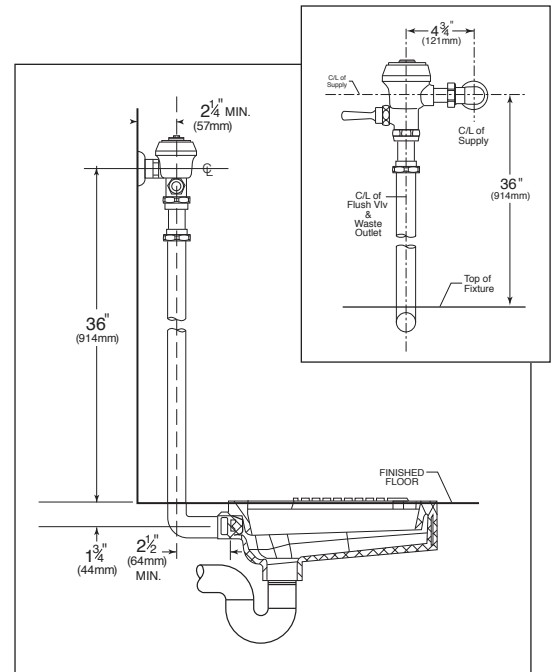

P.O. Box 411 • Charlottesville • VA • 22902 • USA Phone: (434) 296-0166 • Fax (434) 977-3596
Email: info@delanyproducts.com Web: www.delanyproducts.com ©2018 v1



ASSE 1037

