

### TruEDGE

#### Description

Battery powered, sensor activated, diaphragm operated, chrome plated exposed flush valve for 3/4" top spud urinals.

#### Flush Cycle

0.125 gpf/0.5 Lpf High Efficiency

#### Specification

- 3/4" vandle proof TruStop ball valve designed angle control stop with TruChek.
- SmartChoice Technology software provides field. adjustability for True-in-the-Field Water Conservation
- Remote for Range & Discharge Adjustability.
- Mashaerator self-cleaning diaphragm.
- Chloramine resistant diaphragm.
- 6 Volt DC latching solenoid valve.
- 6 Volt DC lithium battery (CR-P2 type).
- Infrared sensor with Dual Infrared Transmitter Technology
- Arming delay of 10 seconds prevents unintentional flushes
- Electronic courtesy flush push button.
- Renewable main valve seat.
- Sweat Adapter Kit.
- Vacuum Breaker w/ 9" flush connection.
- Wall flange, spud nut and spud flange for 3/4" top spud.
- All rubber parts molded of chloramine resistant rubber.

#### Variations

- GJ - Ground Jount Tailpiece
- SC - SlipFit Connection (adjustable joint tailpiece)
- T36 - Solid ring wall support for flush connection

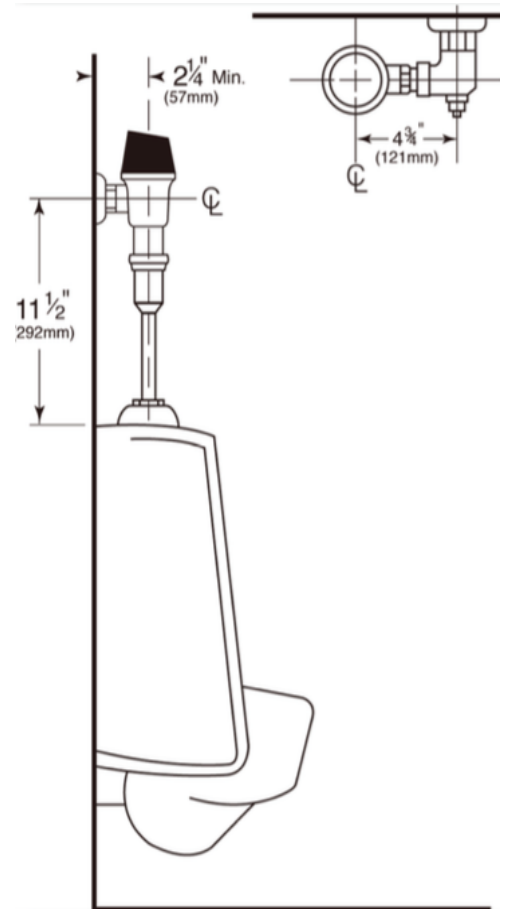

Valve is in compliance with the applicable sections of ASSE 1037.

