

Tru ULTRA Plus

Description

Exposed chrome plated flush valve with TruStop for 3/4" top spud Urinals

Flush Cycle

0.5 gpf / 1.9 Lpf High Efficiency

Specification

- Regulating screw for "True-in-the-Field" water conservation.
- Mashaerator self-cleaning bypass diaphragm.
- ADA compliant metal "Rubberflex" oscillating handle.
- Renewable main valve seat.
- 1" vandle resistant capped screwdriver angle stop with back-check.
- Sweat adapter kit.
- SlipFit adjustable tailpiece.
- 3/4" x 9" vacuum breaker flush connection.
- Wall flange, spud nut and spud flange for 3/4" top spud.
- All rubber parts molded of chloramine resistant rubber.

Variations

- AM - Antimicrobial Coated Handle
- SM - Side mounted battery powered sensor actuator
- T36 - Solid ring wall support for flush connection

Valve is certified to be in compliance to the applicable sections of ASSE 1037 and ANSI/ASME 112.19.2 WaterSense Listed and compliant when paired with a WaterSense compliant fixture.



Patented TruStop Control Stop

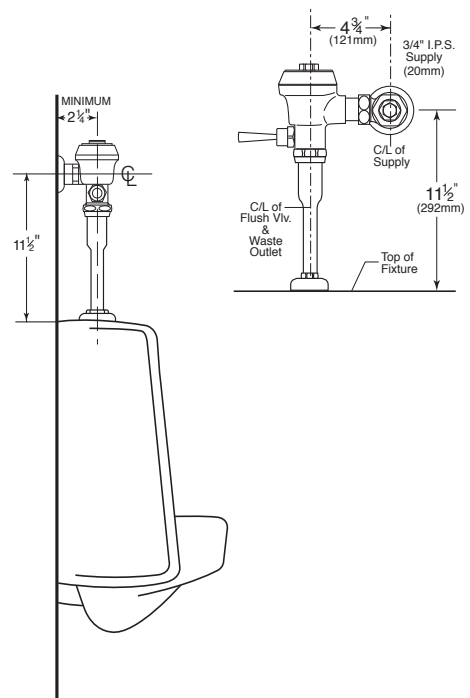

ASSE 1037



Certified by CSA Group